

# A Multi-Band End-Fed Antenna

**Dan Wiley, W6AZI**

After receiving my Technician-class license in 2021, I soon realized that an antenna would be the most important station component to consider for effective operations from my small backyard.

I started by making a list of performance requirements and practical considerations for the design. I wanted to have reasonable DX performance on the CW and digital portions of the 80-, 40-, and 20-meter bands at low power (below 20 W). I also wanted it to be low cost and lightweight, be easy to assemble and disassemble, only require a few alterations to my property, and have minimal grounding requirements and visual impact (see Figure 1).

## The Vertical End-Fed Idea

I scoured the web for compact multi-band antenna designs that can operate down to 80 meters. I came across a popular sloped inverted-L design by Steve Nichols, GØKYA, that I thought might be a good starting point. On GØKYA's *Amateur Radio Blog*, Steve wrote an article titled "A shortened multi-band End-Fed Half Wave (EFHW) antenna for 80-10m" (<https://g0kya.blogspot.com/2017/01/a-shortened-multi-band-end-fed-half.html>). His design includes a loading coil near the far end of the antenna to accommodate 80-meter operation.

My idea was to adapt his design to be vertical. This would allow the takeoff angle to be lower for improved DX operation and would meet my space and aesthetic requirements. The high impedance of a resonant end-fed antenna meets my minimal grounding requirement, as a 12-foot counterpoise is all that's required. I started modeling the antenna with EZNEC ([www.ez nec.com](http://www.ez nec.com)) to work out the dimensions. After a number of iterations, I converged on an overall antenna length of 75.6 feet, which informed my choice for a mast later on. The original GØKYA loading coil value of 110  $\mu\text{H}$  proved to be a good compromise of overall length, impedance, and bandwidth for 80-meter operation.

I found that the Spiderbeam 18-meter (60-foot) telescoping fiberglass mast ([www.spiderbeam.us/product\\_info.php?info=p232\\_Spiderbeam%2018m%20fiberglass%20pole.html](http://www.spiderbeam.us/product_info.php?info=p232_Spiderbeam%2018m%20fiberglass%20pole.html)) best met my

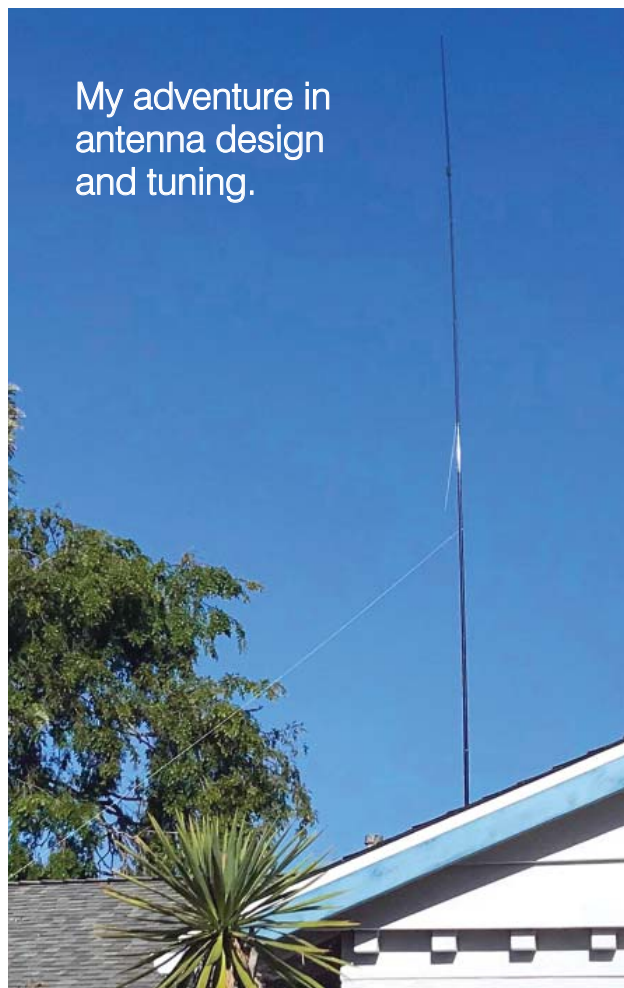

My adventure in antenna design and tuning.

**Figure 1** — The view of the antenna from my front yard. The narrow, black, single-mast design is unobtrusive. So far, no neighbors have complained. The tiny black blob near the top of the mast is the loading coil.

requirements for length, cost, weight, ease of assembly, and aesthetics. Some additional parts that I needed included:

- 1 A 150-foot spool of #18 AWG braided bare copper wire.
- 2 A loading coil form. I purchased a 1.5 × 12-inch sink tailpiece from ACE Hardware (item number 4223392).
- 3 #20 AWG loading coil magnet wire (36 feet).
- 4 Heat shrink for the loading coil that was 7 inches long and had an inside diameter of 2 inches.



▲ **Figure 2** — On the left, the loading coil is shown uncovered, and the right image shows it covered with heat shrink.

► **Figure 3** — A close-up view of the loading coil is on the left, and the right image shows it installed on the mast.



## The Loading Coil Assembly

I made the 110  $\mu\text{H}$  loading coil by close-winding 83 turns of #20 AWG magnet wire around a plastic sink drain tailpiece that was 1.5 inches in diameter and 5 inches long. I drilled holes near the ends of the tube to hold the windings in place and to provide strain relief. After checking the inductance with an LCR meter, I covered the coil with heat shrink to protect it from the elements. I then filled the wire holes from inside the tube with epoxy to keep out moisture (see Figure 2). When installed, the mast runs through the tube, and the coil is secured to the mast with zip ties (see Figure 3).

## Mounting the Mast

The mast must be mounted and guyed safely and securely. I mounted my mast to the corner eaves of my house, about 8 feet above the ground, using two 0.375-inch eye bolts, a 0.5-inch crossbolt, washers, and nuts (see Figure 4). The base of the mast is held in place by a heavy stack of concrete patio bricks. The antenna wire is zip-tied to the mast above the



**Figure 4** — What the mast looks like once it's mounted to the eaves. Note the stack of heavy patio bricks holding the mast in place.

eaves and sloped diagonally down to my window, where it's fed through and connected to my antenna-matching network (see Figure 5).

## Impedance Matching

I used a homebrew L network with a tapped inductor and a variable capacitor to impedance-match the antenna to 50  $\Omega$  (see Figure 6). The schematic can be seen in Figure 7.

## Tuning the Length

Tuning the antenna involves alternately adjusting the length of the short wire between the loading coil and the top of the mast for resonance at 80 meters, and the long wire between the impedance-matching network and the loading coil for resonance at 40 meters. The end result is maximum resistive impedance and minimum reactance at 80 and 40 meters.

I used a RigExpert antenna analyzer with a dual banana adapter connected to the antenna wire and a 12-foot counterpoise to measure the antenna impedance directly. When using this method, it's important to have the antenna wire connected to a bleeder resistor, or temporarily to ground, to discharge any static electricity prior to connecting the antenna to the antenna analyzer. Otherwise, the analyzer can be damaged by electrostatic discharge (ESD), as I once discovered the hard way.

Tuning the length is a tedious process. I had to collapse most of the telescoping sections of the mast every time I needed to adjust the short wire length at the top. Reaching resonance on both bands required several iterations, but this is a necessary step for achieving optimal performance.

## Testing the Antenna

The measured impedances of the antenna range from 2.2 to 5.9 k $\Omega$  at resonance. The SWR plots for the 40- and 20-meter bands are fairly flat, with an SWR of 1.5 or less at each end of the CW and digital portions of each band. The 80-meter 2:1 SWR bandwidth is about 40 kHz wide, due to shortening the antenna with a loading coil. This means the matching network needs to be readjusted if the transmit frequency is changed significantly.

On-air testing met or exceeded my expectations on all bands. From my southern California location (DM04), I am repeatedly able to reach the Neumayer Station III, DP0GVN, in Antarctica on WSPR with only 5 W. After 5 months of FT8 operation, I've

reached a DXCC count of 90, including a contact with Justin Furner, ZS5KT, in South Africa, which is near my antipode. On-air test results and additional details can be found on the QST in Depth web page ([www.arrl.org/qst-in-depth](http://www.arrl.org/qst-in-depth)).

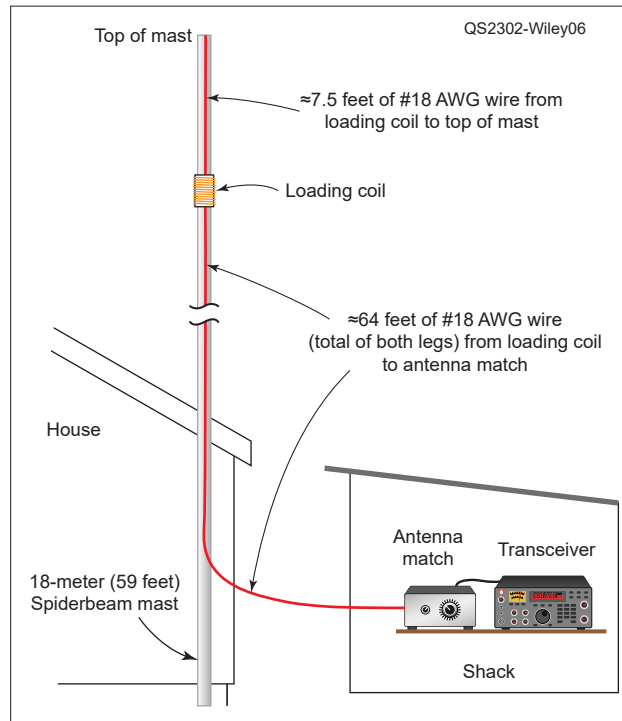

**Figure 5** — A diagram of my antenna. Your wire lengths may vary, depending on the geometry and the proximity to structures when tuned to resonance. The lengths shown here are a reasonable starting point.

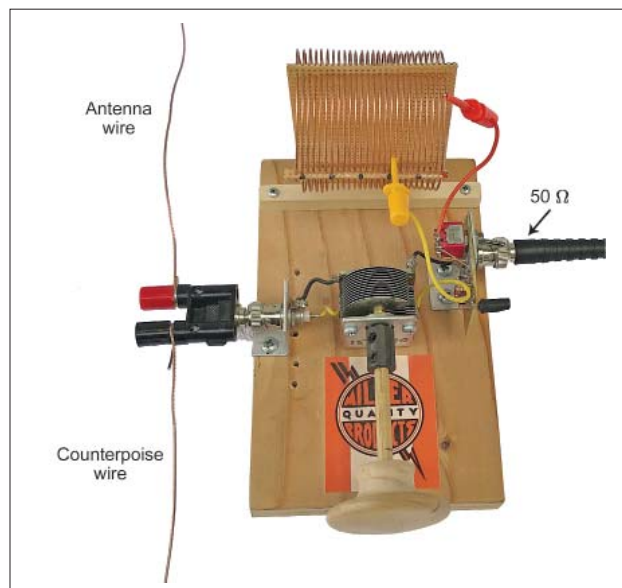

**Figure 6** — My homebrew L network for impedance-matching the antenna.

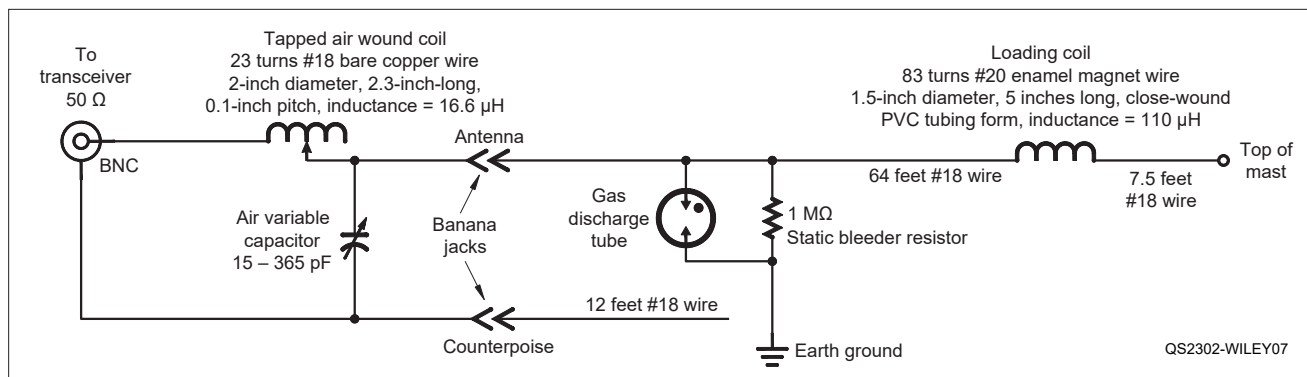

**Figure 7** — The full antenna system schematic showing the matching network, lightning and ESD protection, counterpoise, and antenna connections. A gas discharge tube is used for lightning protection, and a 1 MΩ resistor bleeds off static charges.

## Final Comments

As a newly licensed ham, I couldn't have asked for a more educational project. The process of designing, modeling, constructing, and testing this antenna involved learning about antenna theory and modeling, impedance matching, antenna analyzers, construction techniques, solar weather, radio propagation, the Reverse Beacon Network, FT8, and WSPR. This antenna design met all of my original design goals, and it's been quite satisfying to see it perform well on 80, 40, and 20 meters.

I wish to thank my good friend and mentor Anthony Felino, WN6Q, for his help and support, and for urging me to write this article.

## See QST in Depth for More!

Visit [www.arrl.org/qst-in-depth](http://www.arrl.org/qst-in-depth) for the following supplementary materials and updates:

- ✓ On-air test results
- ✓ Antenna and station improvements

Dan Wiley, W6AZI, worked as an electronic engineer for 43 years, designing image processing and video systems for industrial and medical applications. He is now retired. He received his Technician license in December 2020, and his Amateur Extra-class license in January 2022.

For updates to this article, see the **QST Feedback** page at [www.arrl.org/feedback](http://www.arrl.org/feedback).



All ARRL members can now enjoy the online edition of QEX as a member benefit. Coming up in the January/February 2023 and future QEX issues are articles and technical notes on a range of amateur radio topics. These are at the top of the queue.

- Steven Davidson, K3FZT, designs and builds a Radio Message Server Winlink Gateway.
- Peter DeNeef, AE7PD, estimates diffracted fields inside a building near a window.

- Richard L. Quick, W4RQ, builds a horizontally polarized triangular VHF loop.
- In his essay series, Eric Nichols, KL7AJ, explains filters.
- Brian R. Callahan, AD2BA, and Zhe-min "Hisen" Zhang, KD2TAI, combine artificial intelligence and machine learning in a bot that transcribes heard audio into text.
- Lynn Hansen, KU7Q, reveals a unique method of constructing custom front panels.
- Steve Geers, KA8BUW, uses a microcontroller to build a CW audio filter.

QEX, a forum for the free exchange of ideas among communications experimenters, is edited by Kazimierz "Kai" Siwiak, KE4PT ([ksiwiak@arrl.org](mailto:ksiwiak@arrl.org)),

and is published bimonthly. The printed edition annual subscription rate (six issues per year) for members and non-members in the US is \$29. First-class delivery in the US is available at an annual rate of \$40. For international subscribers, including those in Canada and Mexico, QEX can be delivered by airmail for \$35 annually; see [www.arrl.org/qex](http://www.arrl.org/qex).

Would you like to write for QEX? We pay \$50 per published page for full articles and QEX Technical Notes. Get more information and an Author Guide at [www.arrl.org/qex-author-guide](http://www.arrl.org/qex-author-guide). If you prefer postal mail, send a business-size self-addressed, stamped (US postage) envelope to: QEX Author Guide, c/o Maty Weinberg, ARRL, 225 Main St., Newington, CT 06111.